

HARDLOCK®

on RAILWAY NOISE BARRIER

Tokaido Shinkansen, Japan

Honan High Speed Rail, Korea

Prepared for SMRT

15 Oct 2020

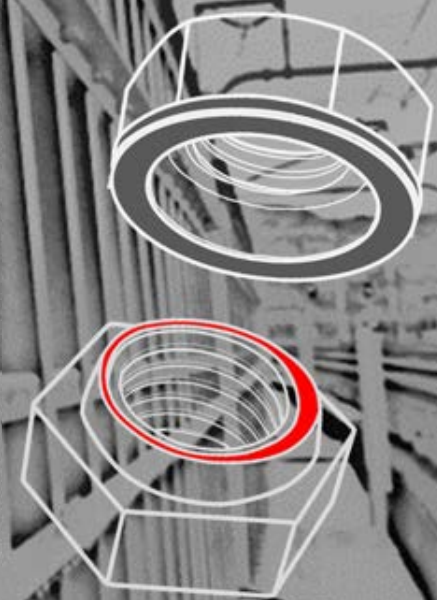

1. External loads applied to noise barrier

Sound barriers are subject to external loads caused by following elements:

- (1) Noise barrier's own weight
- (2) Wind pressure generated by a train passing through
- (3) Wind pressure caused by natural phenomena like typhoon

The following data provide results of field measurements and numerical simulations of wind pressure exciting by passing trains.

Figure 2. shows the wind pressure of a train running at a speed of 252km/h. Wind pressure of +/-0.4kN/m² was measured when the train run into the barrier and +/-0.2kN/m² at the time of going off.

Figure 3. show the relationship between the peak of wind pressure of a train and the train speed. The wind pressure increases exponentially with respect to the train speed.

Authority: 'Dynamic response evaluation of tall noise barrier on high speed railway structures'
Japan Society of Civil Engineering article Vol. 69, No.2, 392-409, 2013

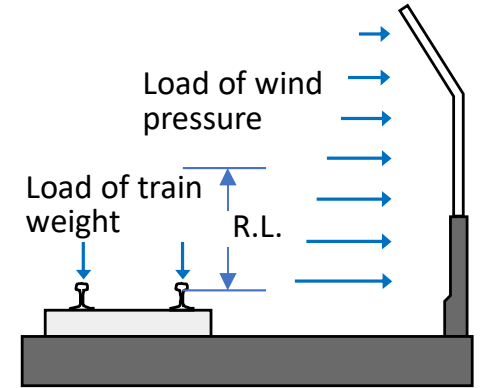

Figure1. Measurement at vertical angle type noise barrier

R.L.: Rail Level

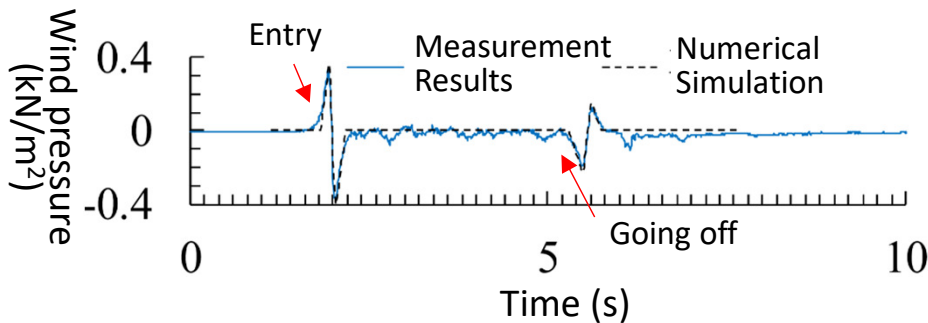
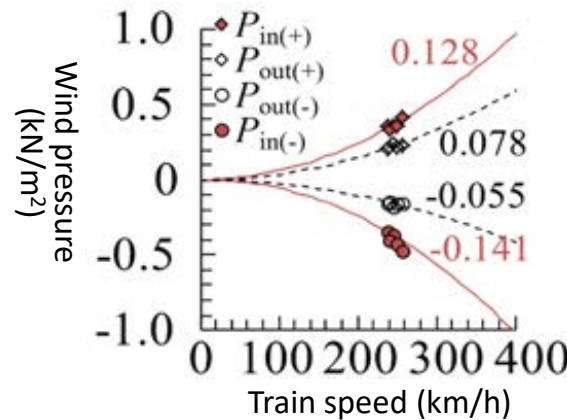
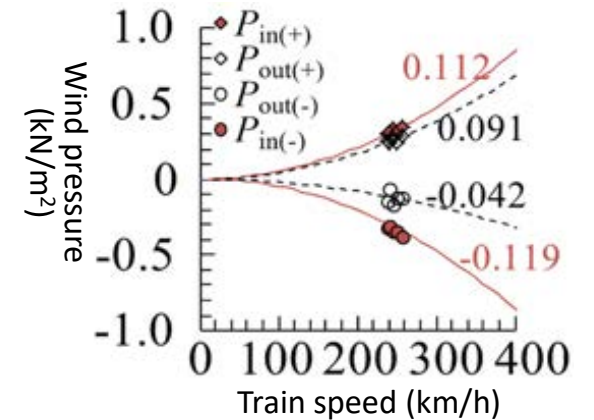

Figure 2. Wind pressure-Time (252km/h)



Barrier: R.L.+4.0m
Meas. Point: from rail 3.8m
R.L.+1.0m



Barrier: R.L.+4.0m
Meas. Point: from rail 3.8m
R.L.+2.5m

The values on the graph are average of pressure coefficient

Figure3. Peak value of wind pressure



2. The nuts competing with HARDLOCK Nuts

While two other nuts had also been used on noise barriers for Shinkansen, now the parts requiring self-locking nuts have been concentrated on HARDLOCK Nuts that have successfully installed for 8 years for following reasons:

New Lock Nut

Produced by West Nippon Expressway Engineering
Kansai Company



The nut becomes inclined due to the tapered area of the washer and the nut thread is in contact with the bottom flank of the bolt, which contributes self-locking effect.

The threads of the bolt and nut come to tight contact.

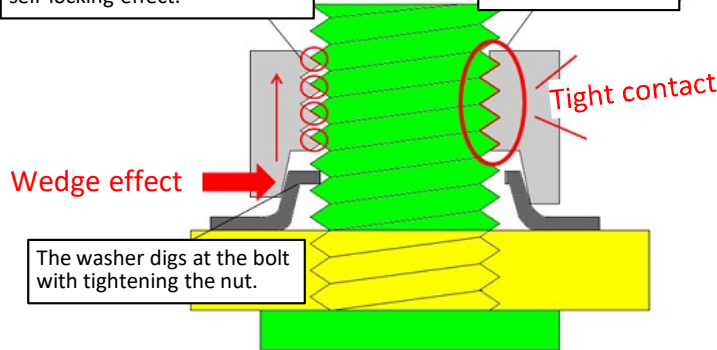

Wedge effect

Tight contact

The washer digs at the bolt with tightening the nut.

Cause of disapproval:
It is difficult to tighten to generate strong clamp force.

U-NUT

Manufactured by Fuji Seimitsu, originally invented by the founder of HARDLOCK Nut

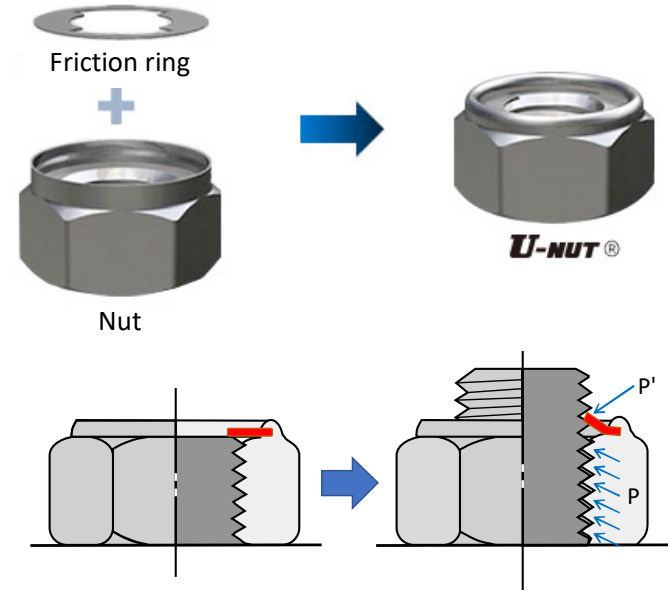

Cause of disapproval: Loosening occurred.



3. Photos of HARDLOCK installation (near Kyoto Station)





4. Supply results for noise barrier for Shinkansen

Unit: pcs

Size	2013	2014	2015	2016	2017	2018	2019	2020	Total
HLN-R M12 HDZ	20,000	253,000	284,000	179,000	301,000	139,000	323,000	79,000	1,578,000
HLN-R M16 HDZ	88,000	128,000	174,000	155,000	188,000	114,000	311,000	188,000	1,346,000
HLN-R M20 HDZ	33,000	78,000	87,000	72,000	73,000	64,000	174,000	86,000	667,000
Total	141,000	459,000	545,000	406,000	562,000	317,000	808,000	353,000	3,591,000

HDZ: Hot Dip Galvanizing

1. Outlines

Installation area of noise barrier: Gwanju - Gomagwon (26km)
Maximum speed: 230km/h
HARDLOCK Nuts installation: M24 SS400: 5,450 sets
M27 SS400: 3,100 sets
Installation: since 2017

The design standard for railway of Ministry of Land, Infrastructure and Transport stipulates that self-locking nuts shall be used to fix the base plate of a steel post.

A structure shall be designed on the basis of:

- Wind pressure of a train passing through
- Vibration of a train passing through
- Regional wind load



Two types of anchor bolt

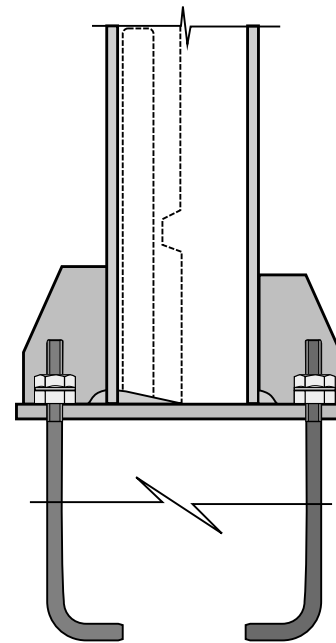

L-bolt

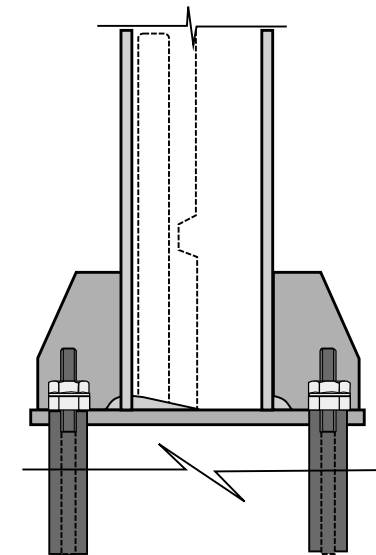

Chemical anchor bolt

2. The nuts competing with HARDLOCK Nuts

Hyperload Nut

To prevent from loosening by means of the prevailing torque created by the mechanical energy of twisted spring

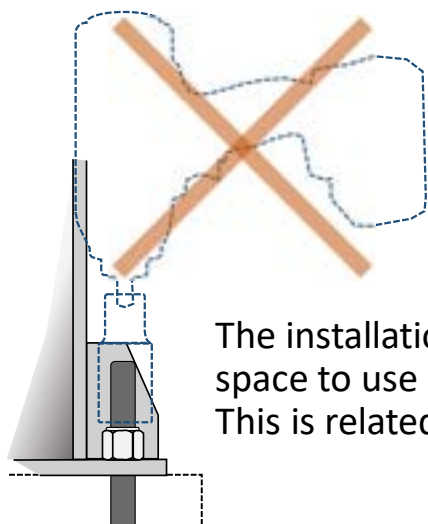
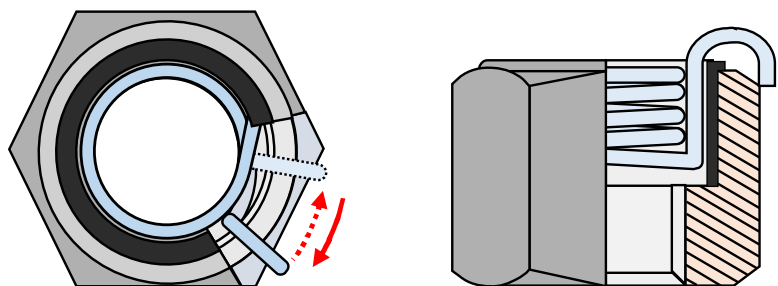

The installation area has no space to use an impact wrench. This is related to the right (1).

Dual-Slotted Locknuts (Lanfranco locknut)

Bolt threads expand depitched slots located in the turret section of the nut, that grip the thread flanks directly creating prevailing torque.

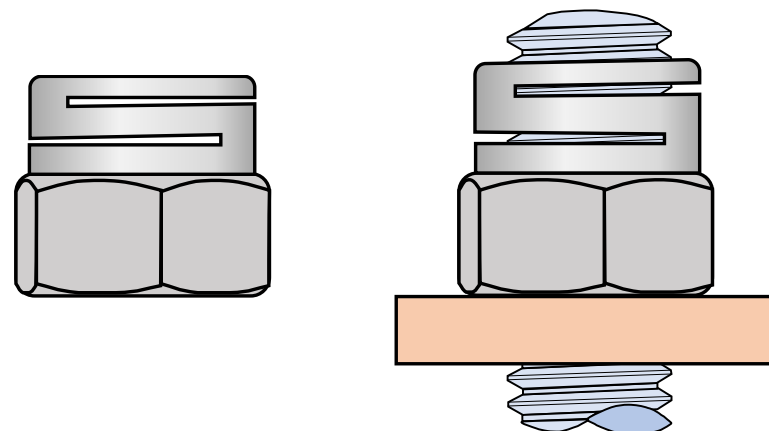

Disadvantage of these nuts being used for the anchor bolts:

- (1) Frictional resistance appears as soon as nuts are engaged with the bolt threads, it is hard work wrenching them to final seated position.
Also, torquing over a long thread travel under load could damage the locking feature.
- (2) In case of Hot Dip Galvanizing, the coating on the threads of bolts is scraped off by frictional resistance, which results in rusting.

3. Advantage of HARDLOCK Nuts being used for noise barrier anchor

- (1) Can be hand-wound before tightening, no scrape-off of the HDZ coating on bolt threads
- (2) The locking effect of HARDLOCK Nuts is independent on the existence of clamp load.
They can even stay fixed (a) on the leaning bolt or (b) over the uneven surface of basement.
- (3) Can retrofit to existing worn bolts

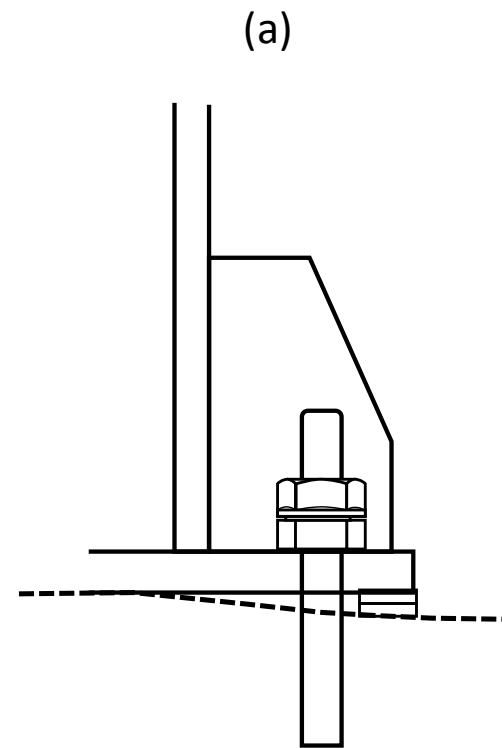
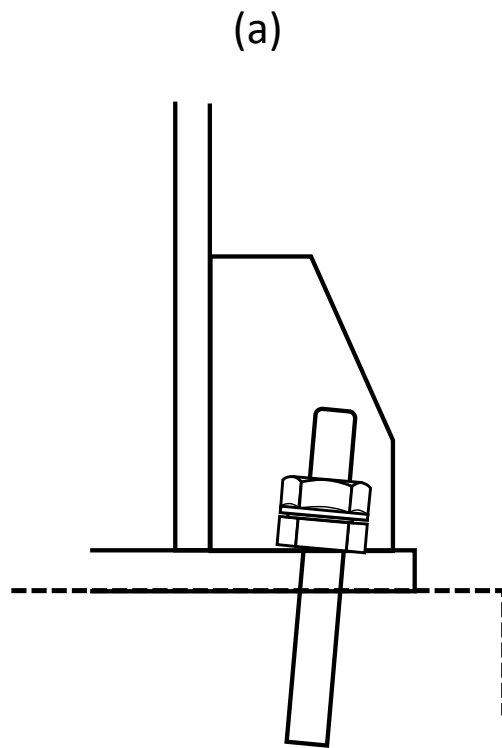

3. Photos of HARDLOCK installation

